



4-Bit Micro-Controller

TM87 series

The solution to “How to avoid the Crystal oscillator being stopped by external interference when BCF flag is cleared to 0?” as TM87 series products applying to 3V power supply and LCD 1/3 bias

Application Note

**Tenx reserves the right to change or
discontinue this product without notice.**

tenx technology inc.

CONTENTS

PRODUCT NAME **2**

TM87 series **2**

 The solution to “How to avoid the Crystal oscillator being stopped by external interference when BCF flag is cleared to 0?” as TM87 series products applying to 3V power supply and LCD 1/3 bias. **2**

APPLICATION NOTE **2**

PRODUCT NAME

TM87 series

TITLE

The solution to “How to avoid the Crystal oscillator being stopped by external interference when BCF flag is cleared to 0?” as TM87 series products applying to 3V power supply and LCD 1/3 bias.

APPLICATION NOTE

Description:

When BCF flag is cleared to 0, IC internal logic circuit will operate under power-saving mode. At this point of time, the Crystal oscillator driver circuit is working under power-saving mode.

In such situations, if there is an instant loss of electricity or interference from external force or touch, the incorrect setting of the BCF Flag will cause the Crystal oscillator stop oscillation. In case of the design has stalled in this situation in mass-production, connect a 2M ohm resistor between VDD2 and the BAK pin (Shown in Figure 1) to help the Crystal oscillator to start-up itself.

But this approach will increase about 750nA of current, and it is only a backup solution to solve the problem in mass-production. In general use, the standard connection is to connect the BAK in series with a capacitor to GND. (Shown in Fig. 2).

It is recommended to clean up the residue on the PCB board, especially around the solder side of the Crystal component. Some experiments reveal that the residue around the Crystal component will cause the Crystal oscillator to stop oscillation in higher humidity.

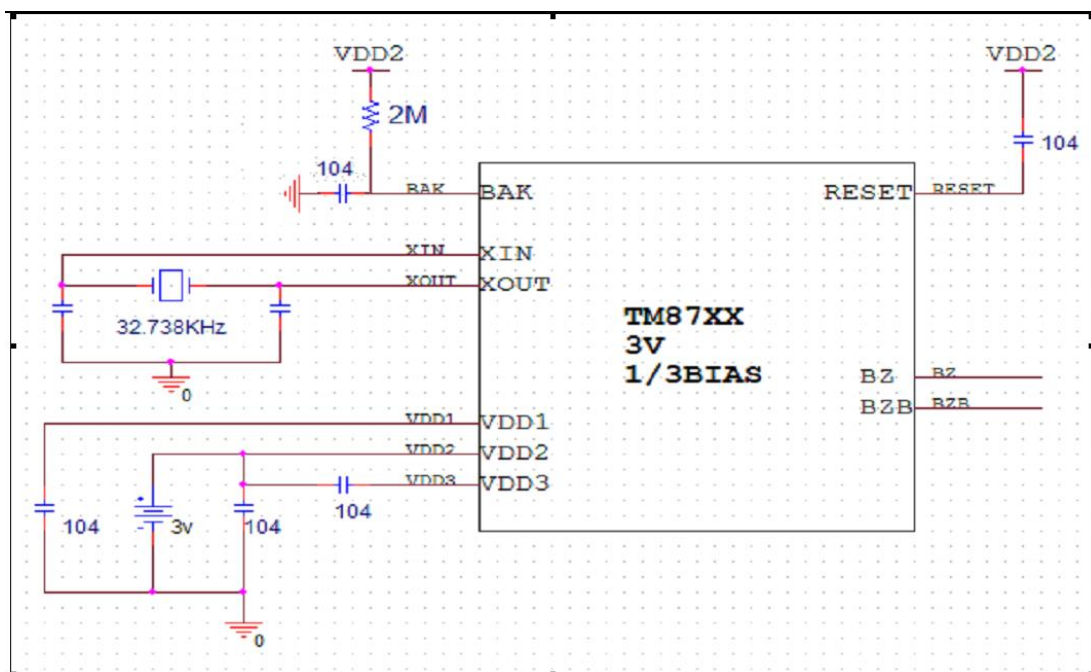

Fig.1

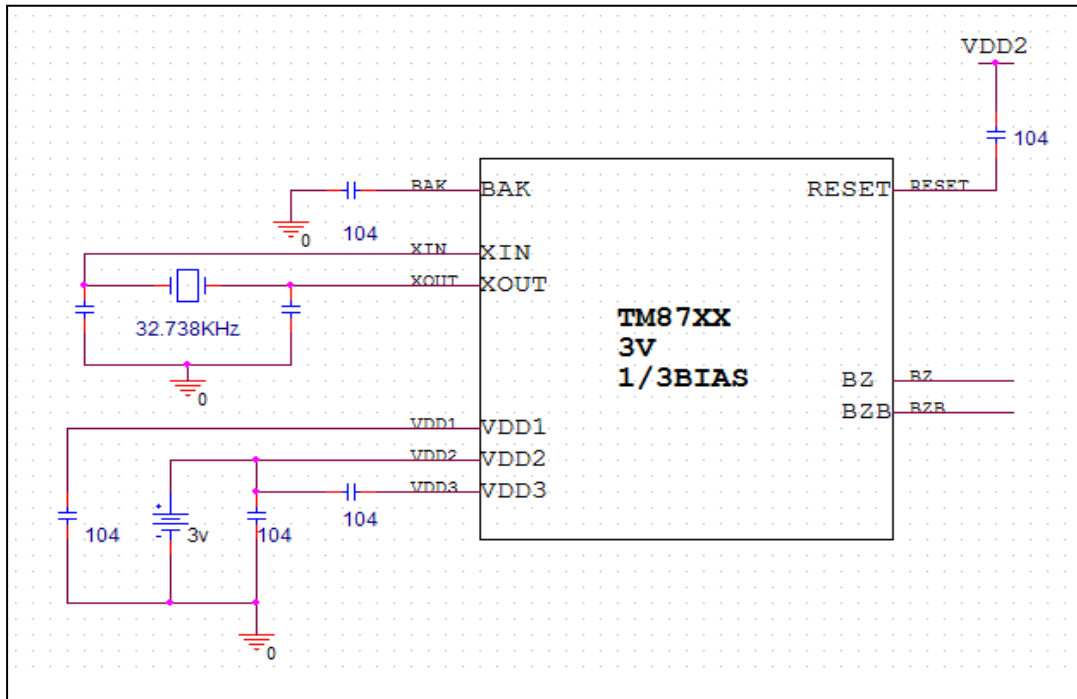

Fig.2

Note : In Fig1, the capacitor in series with BAK to GND is used as a noise filter, if remove it from the circuit (as shown in Fig1), the noise will infiltrate to the MCU when the BCF flag changes, especially in the oscillation system. Therefore, we do not recommend removing this capacitor in an application which the BCF flag changes frequently.