



十速

TM87PL37

DATA SHEET

Rev 1.2

tenx reserves the right to change or discontinue the manual and online documentation to this product herein to improve reliability, function or design without further notice. **Tenx** does not assume any liability arising out of the application or use of any product or circuit described herein; neither does it convey any license under its patent rights nor the rights of others. **Tenx** products are not designed, intended, or authorized for use in life support appliances, devices, or systems. If Buyer purchases or uses tenx products for any such unintended or unauthorized application, Buyer shall indemnify and hold tenx and its officers, employees, subsidiaries, affiliates and distributors harmless against all claims, cost, damages, and expenses, and reasonable attorney fees arising out of, directly or indirectly, any claim of personal injury or death associated with such unintended or unauthorized use even if such claim alleges that tenx was negligent regarding the design or manufacture of the part.

AMENDMENT HISTORY

Version	Date	Description
1.0	Apr, 2022	New Release.
1.1	Jan, 2023	Modify Page.10
1.2	May, 2023	Modify Page.16

CONTENTS

AMENDMENT HISTORY	2
CONTENTS.....	3
GENERAL DESCRIPTION	4
FEATURE.....	4
APPLICATION.....	6
BLOCK DIAGRAM	6
PAD ASSIGNMENT.....	7
PIN DESCRIPTION	8
SERIAL PROGRAM/READ CONNECT PINS:	9
ELECTRICAL CHARACTERISTICS	11
TYPICAL APPLICATION CIRCUIT	16
Appendix A TM87PL37(L/H) Instruction Table	18
Symbol Description	28
MWM/MMW Rm Assignment	29

- Built-in regulator mode for VL1/2 by option.
7. Input/output ports.
- Port IOA 4 pins (with internal pull-low), and can be defined as SEG24~27/CX, RR, RT, RH by option.
 - Port IOB 4 pins (with internal pull-low), and can be defined as SEG28~31/ELC, ELP, BZB, BZ by option.
 - Port IOC 4 pins (with internal pull-low, low-level-hold, input signal chattering prevention circuitry), and can be defined as SEG32~35/KI1~4 by option.
 - Port IOD 4 pins (with internal pull-low, input signal chattering prevention circuitry), and can be defined as SEG36~39 by option.
 - Port IOE 4 pins (with internal pull-low, input signal chattering prevention circuitry), and can be defined as SEG40~43 by option.
 - Port IOF 4 pins (with internal pull-low, input signal chattering prevention circuitry), and can be defined as SEG44~47 by option.
 - Port IOG 4 pins (with internal pull-low, input signal chattering prevention circuitry), and can be defined as SEG48~51 by option.
8. Interrupt function.
- External factors 4 (INT pin, Port IOC, IOD & KI input).
 - Internal factors 4 (Pre-Divider, Timer1, Timer2 & RFC).
9. Built-in EL-light driver.
- ELC, ELP. Can be defined as SEG28, 29/IOB1, 2 by option.
10. Built-in Alarm, clock or single tone melody generator.
- BZB, BZ. Can be defined as SEG30, 31/IOB3, 4 by option.
11. Built-in resistance to frequency converter.
- CX, RR, RT, RH. Can be defined as SEG24~27/IOA1~4 by option.
12. Built-in key matrix scanning function.
- KO1~KO16 (Shared with SEG1~16)
 - KI1~KI4. Can be defined as SEG32~35/IOC1~4 by option.
13. Two 6-bit programmable timers with programmable clock source.
- Read out the content in anytime
14. Watchdog timer.
15. Built-in voltage charge halver & pump circuit.
16. Dual clock operation
- slow clock oscillation can be defined as X'tal or external RC type oscillator by option.
 - fast clock oscillation can be defined as 3.58MHz ceramic resonator, internal R or external R type oscillator by option.

- 17. HALT function.
- 18. STOP function.
- 19. Built-in Low Battery Detect.
- 20. Built-in Low Voltage Reset(2 type).

APPLICATION

- Timer/Calendar/Calculator/Thermometer

BLOCK DIAGRAM

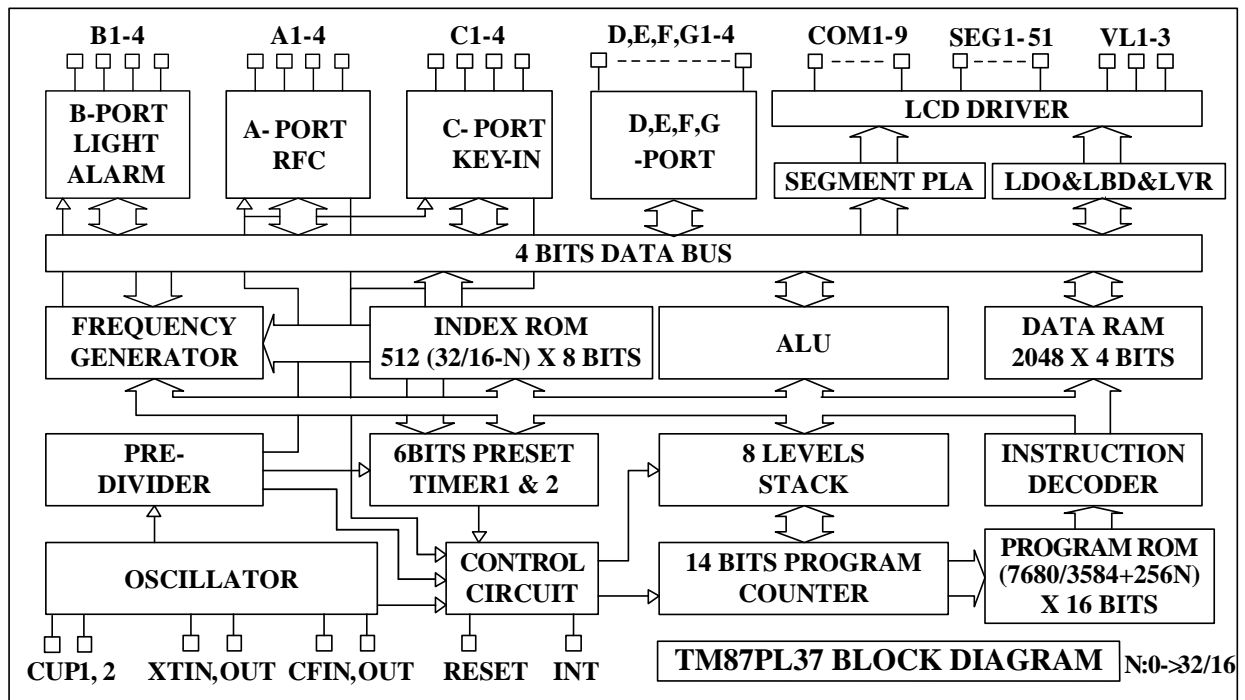

PAD ASSIGNMENT

No	Name	No	Name
1	BAK	41	SEG21
2	XIN	42	SEG22
3	XOUT	43	SEG23
4	CFIN	44	SEG24/IOA1/CX
5	CFOUT	45	SEG25/IOA2/RR
6	GND	46	SEG26/IOA3/RT
7	VL1<VDD1>	47	SEG27/IOA4/RH
8	VL2<VDD2>	48	SEG28/IOB1/ELC
9	VL3<VDD3>	49	SEG29/IOB2/ELP
10	CUP1	50	SEG30/IOB3/BZB
11	CUP2	51	SEG31/IOB4/BZ
12	COM1/COM9^/SEG31	52	SEG32/IOC1/KI1
13	COM2/COM8^/SEG32	53	SEG33/IOC2/KI2
14	COM3/COM7^/SEG33	54	SEG34/IOC3/KI3
15	COM4/COM6^/SEG34	55	SEG35/IOC4/KI4
16	COM5/COM5^/SEG35	56	SEG36/IOD1
17	COM6/COM4^/SEG36	57	SEG37/IOD2
18	COM7/COM3^/SEG37	58	SEG38/IOD3
19	COM8/COM2^/SEG38	59	SEG39/IOD4
20	COM9/COM1^/SEG39	60	SEG40/IOE1
21	SEG1 (K1)	61	SEG41/IOE2
22	SEG2 (K2)	62	SEG42/IOE3
23	SEG3 (K3)	63	SEG43/IOE4
24	SEG4 (K4)	64	SEG44/IOF1
25	SEG5 (K5)	65	SEG45/IOF2
26	SEG6 (K6)	66	SEG46/IOF3
27	SEG7 (K7)	67	SEG47/IOF4
28	SEG8 (K8)	68	SEG48/IOG1
29	SEG9 (K9)	69	SEG49/IOG2
30	SEG10 (K10)	70	SEG50/IOG3
31	SEG11 (K11)	71	SEG51/IOG4
32	SEG12 (K12)	72	RESET (VPP)
33	SEG13 (K13)	73	INT
34	SEG14 (K14)	74	VBAT
35	SEG15 (K15)		
36	SEG16 (K16)		
37	SEG17		
38	SEG18		
39	SEG19		
40	SEG20		

Symbol Description

'<>' : Pin name in TM8727

'()' : Attached function

'/' : Option function

'^' : Mirror Pin Name

PIN DESCRIPTION

Name	I/O	Description
BAK	P	Positive Back-up voltage. If BAK=VL1/2 or VREG at BCF=0, connect a 0.1uF capacitor to GND. Positive voltage is need to BAK for Serial Program/Read Mode.
VBAT	P	Positive supply voltage. Positive voltage is need to VBAT for Serial Program/Read Mode.
VL1~3	P	LCD supply voltage. In 1.5V Power Mode & “LCD CHARGE PUMP MODE” option= “VL1 (NO REGULATOR)”, connect positive power output to VL1. In 3V Power mode & “LCD CHARGE PUMP MODE” option= “VL1(NO REGULATOR)” or “VL2 (NO REGULATOR)”, connect positive power to VL2. If “LCD CHARGE PUMP MODE” option= “VDL (1.05V)” or “VDL (2.10V)”, connect Capacitors to VL1~3 For 1/3Bias by Capacitor Voltage Divider mode, connect positive power to VL3. Positive voltage is need to VL3 for Serial Program/Read Mode.
RESET	I	Input pin for external reset request signal, built-in internal pull-down resistor. High voltage is need to RESET pin for Serial Program/Read Mode.
INT	I	Input pin for external INT request signal. • Falling edge or rising edge triggered is defined by option. • Internal pull-down or pull-up resistor is defined by option.
CUP1,2	O	Switching pins for supply the LCD driving voltage to the VL1~3 pins. • Connect the CUP1 to CUP2 pins with non-polarized electrolytic capacitors when chip operated in 1/2 or 1/3 bias mode.
XIN XOUT	I O	Low speed oscillator, generates clock for time base functions (clock specified. LCD alternating frequency. Alarm signal frequency) or system clock oscillation. • The usage of 32 KHz Crystal oscillator or external RC oscillator is defined by option.
CFIN CFOUT	I O	High speed oscillator, system clock oscillation for FAST clock only or DUAL clock operation. The usage of 3.58 MHz ceramic/resonator oscillator or external R type oscillator is defined by option
COM1~9	O	Output pins for driving the common pins of the LCD panel. COM1~9 pins can be mirrored to COM9~1 by option. COM1~9 can be defined as COMS or Open Drain type output by option. COM2~9/9~2 can be defined as SEG32~39/31~38 by option. COM1 & SEG24 force same PSTB & DBUS option for CMOS or P_open drain type output.
SEG1-51	O	Output pins for driving the LCD panel segment. SEG24~27 can be defined as IOA1~4/CX, RR, RT, RH by option. SEG28~31 can be defined as IOB1~4/ELC, ELP, BZB, BZ by option. SEG32~35 can be defined as IOC1~4/KI1~4 by option. SEG36~39 can be defined as IOD1~4 by option. SEG40~43 can be defined as IOE1~4 by option. SEG44~47 can be defined as IOF1~4 by option. SEG48~51 can be defined as IOG1~4 by option. SEG1~51 can be defined as COMS or Open Drain type output by option.
IOA1-4	I/O	Input/Output port A, and can be defined as SEG24~27/CX,RR,RT,RH by option.
IOB1-4	I/O	Input/Output port B, and can be defined as SEG28~31/ELC, ELP, BZB, BZ by option.
IOC1-4	I/O	Input/Output port C, and can be defined as SEG32~35/KI1~4 by option. IOC3, 4 is Signal for Serial Program/Read Mode.
IOD1~4	I/O	Input/Output port D, and can be defined as SEG36~39 by option.
IOE1~4	I/O	Input/Output port E, and can be defined as SEG40~43 by option.
IOF1~4	I/O	Input/Output port F, and can be defined as SEG44~47 by option.
IOG1~4	I/O	Input/Output port G, and can be defined as SEG48~51 by option.

Name	I/O	Description
CX	I	1 input pin and 3 output pins for RFC application, and can be defined as
RR,RT,RH	O	SEG24~27/IOA1~4 by option.
ELC/ELP	O	Output port for EI panel driver, and can be defined as SEG28, 29/IOB1, 2 by option.
BZB/BZ	O	Output port for alarm, clock or single tone melody generator, and can be defined as SEG30, 31/IOB3, 4 by option.
KO1~KO16	O	Output port for key matrix scanning, shared with SEG1~16.
KI1~4	I	Input port for key matrix scanning, and can be defined as SEG32~35/IOC1~4 by option.
GND	P	Negative supply voltage.

SERIAL PROGRAM/READ CONNECT PINS:

VBAT, BAK, VL3, GND, RESET, IOC3, IOC4

ABSOLUTE MAXIMUM RATINGS

GND=0V

Name	Symbol	Range	Unit
Maximum Supply Voltage	VBAT	-0.3 to 3.6	V
	VL1	-0.3 to 2.1	
	VL2	-0.3 to 3.6	
	VL3	-0.3 to 6.0	
	VL4	-0.3 to 6.0	
	VL5	-0.3 to 6.0	
Maximum Input Voltage	Vin1	-0.3 to VBAT +0.3	
	Vin2	-0.3 to VL1/2 +0.3	
Maximum output Voltage	Vout1	-0.3 to VBAT +0.3	
	Vout2	-0.3 to VL1/2 +0.3	
	Vout3	-0.3 to VL3 +0.3	
	Vout4	-0.3 to VL4 +0.3	
	Vout5	-0.3 to VL5 +0.3	
Maximum Operating Temperature	Topg	-40 to +80	°C
Maximum Storage Temperature	Tstg	-40 to +125	

ALLOWABLE OPERATING CONDITIONS

at #1: 1.5V Power Mode Ta= -20°C to 70°C, GND=0V

at #2: 3V Power Mode (BCF=0: BAK<VBAT) , Ta= -20°C to 70°C, GND=0V

at #3: 3V Power Mode (BCF=0: BAK=VBAT) , Ta= -40°C to 80°C, GND=0V

Crystal Mode condition: XIN&XOUT with 15pF & 15pF match capacitors

Name	Symb.	Condition	Min.	Max.	Unit	
Supply LCD Voltage	VL1		0.95	1.8	V	
	VL2		1.8	3.6		
	VL3		1.8	5.4		
Oscillator Start-Up Voltage	BAK	Crystal Mode BCF=1, #1	1.4			
		Crystal Mode BCF=1, #2	1.5			
		Crystal Mode BCF=1, #3	1.6			
Oscillator Sustain Voltage	BAK	Crystal Mode BCF=0, #1	1.1	1.8		
		Crystal Mode BCF=0, #2	1.1	3.6		
		Crystal Mode BCF=0, #3	1.3	3.6		
Supply Voltage	BAK		1.2*1	3.6		
	VBAT	1.5V Power Mode without regulator	1.2*1	1.8		
		1.5V Power Mode with regulator	1.35*1	1.8		
		3V Power Mode without regulator BAK=VBAT for BCF=0	1.8	3.6		
		3V Power Mode without regulator BAK=VL1 for BCF=0	2.4	3.6		
		3V Power Mode with regulator VL2=VDL	2.0	3.6		
		3V Power Mode with regulator VL1=VDL	1.8	3.6		
Input "H" Voltage	Vih1	I/O, INT, RESETB, CX	0.8xVBAT	VBAT		
Input "L" Voltage	Vil1		0	0.2 x VBAT		
Input "H" Voltage	Vih2	OSCIN	0.8xBAK	BAK		
Input "L" Voltage	Vil2		0	0.2 x BAK		
Operating Freq	Fopg1	Crystal Mode	32			KHz
	Fopg2	RC Mode	10	4096		
	Fopg3	CF Mode	1000	4096		
Power-down stable time before Power-on reset activation	Tpds	Va= 0.1xVBAT	1			S
Power-on reset activation power rise time	Tpor	Va/Vb=0.1/0.9 x VBAT VBAT>=1.2V		10		mS

*1: Crystal mode need take care Oscillator Start-Up Voltage.

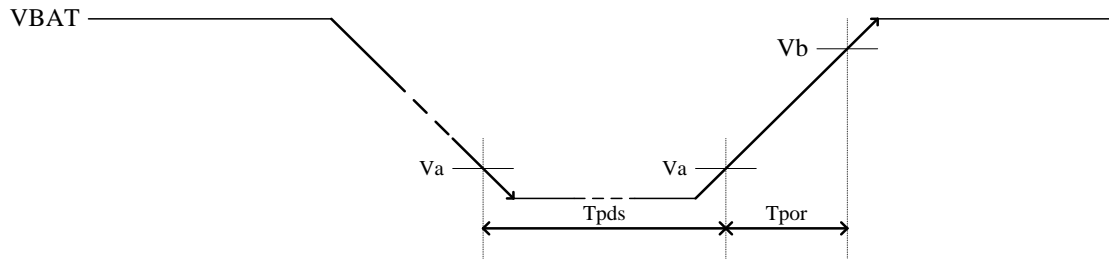

ALLOWABLE OPERATING FREQUENCY

at Ta= -40°C to 80°C, GND=0V

Condition	Maximum Operating Frequency
BAK=1.2V	1 MHz
BAK=1.8V	4 MHz
BAK=2.2V	6 MHz

ELECTRICAL CHARACTERISTICS

Power Consumption

at Ta= -40°C to 80°C, GND=0V

Halt Condition: BCF=0, 1/3Bias, 1/6Duty, LCD Alternating Frequency=PH5, Charge Pump Cycle=PH4, Only 32.768 KHz Crystal oscillator operating, without loading.

Name	Sym.	Condition	Min.	Typ.	Max.	Unit
HALT mode	IHALT1	1.5V Power Mode, VBAT=1.5V		5		uA
	IHALT2	3V Power Mode (BCF=0=> BAK=VL1), VBAT=3.0V		2		
	IHALT3	3V Power Mode (BCF=0=> BAK=VBAT), VBAT=3.0V		10		
STOP mode (VBAT=3.0V)	ISTOP1	Disable LVR1 & Regulator & LVR2			1	
	ISTOP2	Enable LVR1		0.2	1.5	
	ISTOP3	Enable Regulator or LVR2		1	3	

Note: When RC oscillator function is operating, the current consumption will depend on the frequency of oscillation.

Internal RC Frequency Range

Ta= -40°C to 80°C, GND=0V

Option Mode	BAK	Min.	Typ.	Max.
2 MHz	1.5V	0.6 MHz	1.6 MHz	2.6 MHz
	3.0V	1.0 MHz	2.0 MHz	3.0 MHz

Input Resistance

at #1: VBAT=1.5V (1.5V Power Mode)

at #2: VBAT=3.0V (3V Power Mode)

at Ta= -40°C to 80°C, GND=0V

Name	Symb.	Condition	Min.	Typ.	Max.	Unit
“L” Level Hold Tr. (IOC)	Rllh1	Vi=0.2VBAT, #1	10	40	100	KΩ
	Rllh2	Vi=0.2VBAT, #2	10	40	100	
IOA, B, C, D, E Pull-Down Tr.	Rmad1	Vi=VBAT, #1	200	500	1000	
	Rmad2	Vi=VBAT, #2	200	500	1000	
INT Pull-up Tr.	Rintu1	Vi=VBAT, #1	50	200	1000	
	Rintu2	Vi=VBAT, #2	50	350	1000	
INT Pull-Down Tr.	Rintd1	Vi=GND, #1	200	500	1000	
	Rintd2	Vi=GND, #2	200	500	1000	
RES Pull-Up R	Rres1	Vi=GND or VBAT, # 1	10	40	100	
	Rres2	Vi=GND or VBAT, #2	10	40	100	

DC Output Characteristics

at #1: VBAT=1.2V

at #2: VBAT=2.4V

at Ta= -40°C to 80°C, GND=0V

Name	Symb.	Condition	Port	Min.	Typ.	Max.	Unit	
Output “H” Voltage	Voh1a	Ioh= -100uA, #1	COM1~9 & SEG1~51 (for DC/OD), IOB~G, ELC, ELP, BZB, BZ	1.0			V	
	Voh2a	Ioh= -1mA, #2		2.0				
Output “L” Voltage	Vol1a	Iol=200uA, #1				0.2		
	Vol2a	Iol=2mA, #2				0.4		
Output “H” Voltage	Voh1b	Ioh= -200uA, #1		IOA, RR, RT, RH, INT&CX (Vol only)	1.0			
	Voh2b	Ioh= -3mA, #2			2.0			
Output “L” Voltage	Vol1b	Iol=400uA, #1				0.2		
	Vol2b	Iol=5mA, #2				0.4		
Output “L” Voltage	Vol2c	Iol=40mA, #2	COM1~9 (for LED)			0.6		

Segment Driver Output Characteristics

at #1: VL1=1.2V

at #2: VL2=2.4V

at #3: VL1=1.05V

at #4: VL2=2.10V

at #5: VL3=2.4V

Name	Symb.	Condition	For	Min.	Typ.	Max.	Unit.
Static display Mode							
Output “H” Voltage	Voh12f	Ioh= -1uA, #1, #2	SEG-n	2.2			V
	Voh34f	Ioh= -1uA, #3		1.90			
Output “L” Voltage	Vol12f	Iol=1uA, #1, #2				0.2	
	Vol34f	Iol=1uA, #3, #4				0.2	

Name	Symb.	Condition	For	Min.	Typ.	Max.	Unit.	
Output “H” Voltage	Voh12g	Ioh=-10uA, #1, #2	COM-n	2.2			V	
	Voh34g	Ioh=-10uA, #3		1.90				
Output “L” Voltage	Vol12g	Iol=10uA, #1, #2				0.2		
	Vol34g	Iol=10uA, #3				0.2		
1/2 Bias display Mode								
Output “H” Voltage	Voh12f	Ioh= -1uA, #1, #2	SEG-n	2.2			V	
	Voh34f	Ioh= -1uA, #3		1.90				
Output “L” Voltage	Vol12f	Iol=1uA, #1, #2				0.2		
	Vol34f	Iol=1uA, #3, #4				0.2		
Output “H” Voltage	Voh12g	Ioh= -10uA, #1, #2	COM-n	2.2				
	Voh34g	Ioh= -10uA, #3		1.90				
Output “M1” Voltage	Vom112g	Iol/h= +/-10uA, #1, #2		1.0		1.4		
	Vom134g	Iol/h= +/-10uA, #3		0.85		1.25		
Output “L” Voltage	Vol12g	Iol=10uA, #1, #2				0.2		
	Vol34g	Iol=10uA, #3				0.2		
1/3 Bias display Mode								
Output “H” Voltage	Voh12h	Ioh= -1uA, #1, #2	SEG-n	3.4			V	
	Voh34h	Ioh= -1uA, #3, #4		2.95				
	Voh5h	Ioh= -1uA, #5		2.2				
Output “M1” Voltage	Vom112h	Iol/h= +/-1uA, #1, #2		1.0		1.4		
	Vom134h	Iol/h= +/-1uA, #3, #4		0.85		1.25		
	Vom15h	Iol/h= +/-1uA, #5		0.6		1.0		
Output “M2” Voltage	Vom212h	Iol/h= +/-1uA, #1, #2		2.2		2.6		
	Vom234h	Iol/h= +/-1uA, #3, #4		1.95		2.30		
	Vom25h	Iol/h= +/-1uA, #5		1.4		1.8		
Output “L” Voltage	Vol12h	Iol=1uA, #1, #2				0.2		
	Vol34h	Iol=1uA, #3, #4				0.2		
	Vol5h	Iol=1uA, #5				0.2		
Output “H” Voltage	Voh12i	Ioh= -10uA, #1, #2		COM-n	3.4			
	Voh34i	Ioh= -10uA, #3, #4			2.95			
	Voh5i	Ioh= -1uA, #5			2.2			
Output “M1” Voltage	Vom112i	Iol/h= +/-10uA, #1, #2	1.0			1.4		
	Vom134i	Iol/h= +/-10uA, #3, #4	0.85			1.25		
	Vom15i	Iol/h= +/-10uA, #5	0.6			1.0		
Output “M2” Voltage	Vom212i	Iol/h= +/-10uA, #1, #2	2.2			2.6		
	Vom234i	Iol/h= +/-10uA, #3, #4	1.90			2.30		
	Vom25i	Iol/h= +/-10uA, #5	1.4			1.8		
Output “L” Voltage	Vol12i	Iol=10uA, #1, #2				0.2		
	Vol34i	Iol=10uA, #3, #4				0.2		
	Vol5i	Iol=10uA, #5				0.2		

Regulator & Low-Battery-Detect Circuit Characteristics

at Ta= -20°C to 70°C, GND= 0V

Name	Symb.	Condition	Min.	Typ.	Max.	Unit
VREG regulator output for BAK	VREG	VDX3~0=F	Typ. -4%	1.95	Typ. +4%	V
		VDX3~0=E		1.90		
		VDX3~0=D		1.85		
		VDX3~0=C		1.80		
		VDX3~0=B		1.75		
		VDX3~0=A		1.70		
		VDX3~0=9		1.65		
		VDX3~0=8		1.60		
		VDX3~0=7		1.55		
		VDX3~0=6		1.50		
		VDX3~0=5		1.45		
		VDX3~0=4		1.40		
		VDX3~0=3		1.35		
		VDX3~0=2		1.30		
		VDX3~0=1		1.25		
VDX3~0=0	1.20					
VDL regulator output for VL2 or BAK & for 3V Power Mode only & initial=2.10V	VDL	VDL3~0=F	Typ. -4%	2.55	Typ. +4%	V
		VDL3~0=E		2.50		
		VDL3~0=D		2.45		
		VDL3~0=C		2.40		
		VDL3~0=B		2.35		
		VDL3~0=A		2.30		
		VDL3~0=9		2.25		
		VDL3~0=8		2.20		
		VDL3~0=7		2.15		
		VDL3~0=6		2.10		
		VDL3~0=5		2.05		
		VDL3~0=4		2.00		
		VDL3~0=3		1.95		
		VDL3~0=2		1.90		
		VDL3~0=1		1.85		
VDL3~0=0	1.80					
VDL regulator output for VL1 & initial=1.05V	VDL	VDL3~0=F	Typ. -4%	1.70	Typ. +4%	V
		VDL3~0=E		1.65		
		VDL3~0=D		1.60		
		VDL3~0=C		1.55		
		VDL3~0=B		1.50		
		VDL3~0=A		1.45		
		VDL3~0=9		1.40		
		VDL3~0=8		1.35		
		VDL3~0=7		1.30		
		VDL3~0=6		1.25		
		VDL3~0=5		1.20		
		VDL3~0=4		1.15		
		VDL3~0=3		1.10		

Name	Symb.	Condition	Min.	Typ.	Max.	Unit		
		VDL3~0=2		1.05				
		VDL3~0=1		1.00				
		VDL3~0=0		0.95				
VREG Stable time, BAK with 0.1 uF Capacitor	TREG				600	mS		
LBD voltage	VLBD	LBD4~0=1F	Typ. -5%	2.90	Typ. +5%	V		
		LBD4~0=1E		2.85				
		LBD4~0=1D		2.80				
		LBD4~0=1C		2.75				
		LBD4~0=1B		2.70				
		LBD4~0=1A		2.65				
		LBD4~0=19		2.60				
		LBD4~0=18		2.55				
		LBD4~0=17		2.50				
		LBD4~0=16		2.45				
		LBD4~0=15		2.40				
		LBD4~0=14		2.35				
		LBD4~0=13		2.30				
		LBD4~0=12		2.25				
		LBD4~0=11		2.20				
		LBD4~0=10		2.15				
		LBD4~0=0F		2.10				
		LBD4~0=0E		2.05				
		LBD4~0=0D	2.00					
				LBD4~0=0C	Typ. -0.1	1.95	Typ. +0.1	V
				LBD4~0=0B		1.90		
				LBD4~0=0A		1.85		
				LBD4~0=09		1.80		
				LBD4~0=08		1.75		
				LBD4~0=07		1.70		
				LBD4~0=06		1.65		
				LBD4~0=05		1.60		
				LBD4~0=04		1.55		
				LBD4~0=03		1.50		
				LBD4~0=02		1.45		
				LBD4~0=01		1.40		
				LBD4~0=00		1.35		
LBD circuit response time	TLBD							
LVR2 circuit response time	TLVR2				1	mS		

Note: VREG & VDL : at VBAT=3.0/1.5V & voltage of option < VBAT for TM87PL37H/L

Low-Voltage-Reset Circuit Characteristics

at Ta= -40/20°C to 80/70°C, GND=0V for LVR1/2

Name	Symb.	Condition	Min.	Typ.	Max.	Unit
LVR1 Reset Voltage	Vlvr1	3V Power Mode Only	0.90	1.50	2.55	V
LVR2 Reset Voltage	Vlvr2	Code option	Typ. -5%	2.90	Typ. +5%	V
				2.85		
2.80						
2.75						
2.70						
2.65						
2.60						
2.55						
2.50						
2.45						
2.40	Typ. -0.1	Typ. +0.1	V			
2.35						
2.30						
2.25						
2.20						
2.15						
2.10						
2.05						
2.00						
1.95						
1.90						
1.85						
1.80						
1.75						
1.70						
1.65						
1.60						
1.55						
1.50						
1.45						
1.40 *1						
1.35 *1						

*1 : Ta= 0°C to 70°C, GND= 0V

TYPICAL APPLICATION CIRCUIT

This application circuit is simply an example, and is not guaranteed to work.

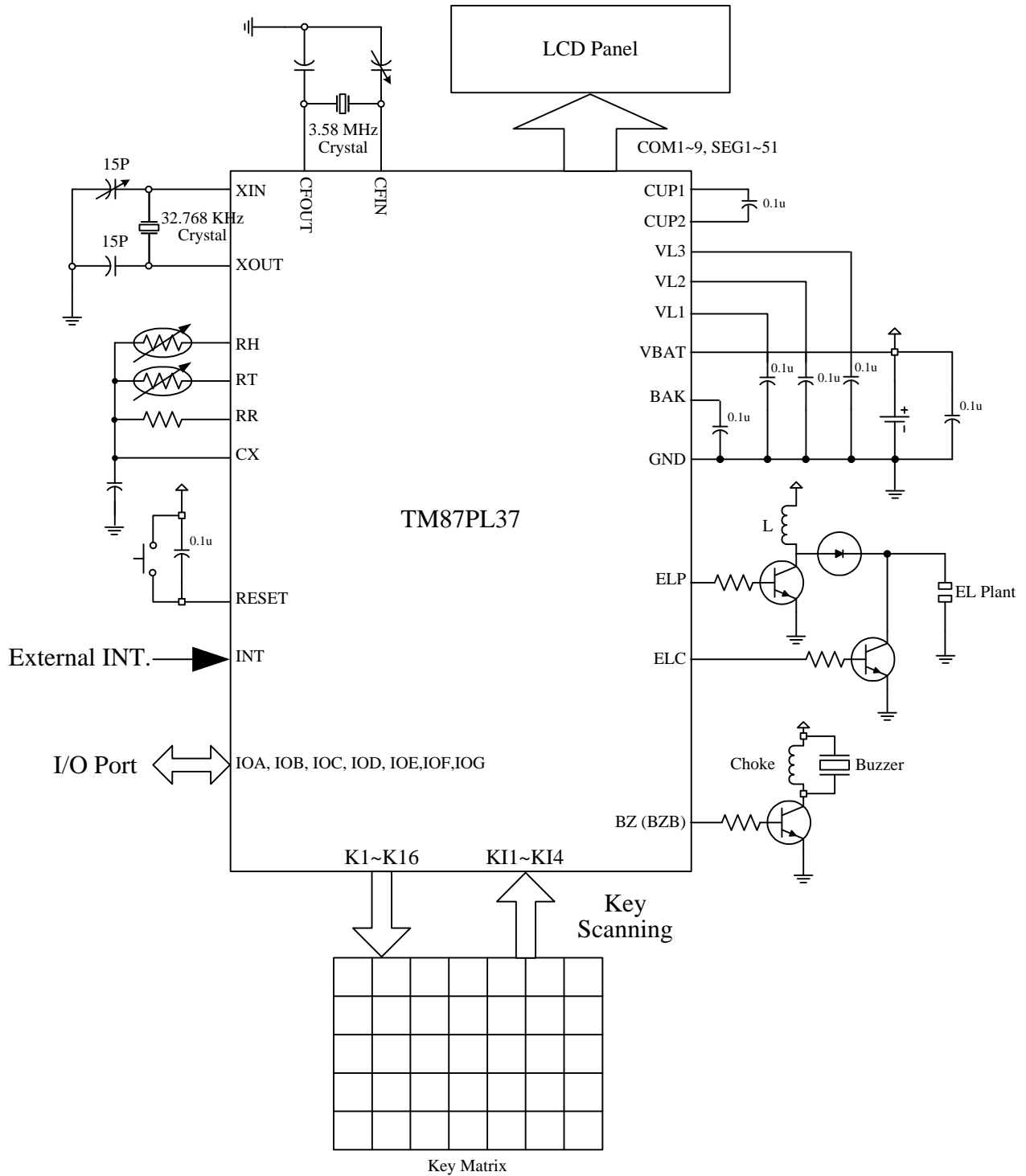

Regulator used for BAK & VL mode, 1/3 Bias, 1/9 Duty

Appendix A TM87PL37(L/H) Instruction Table

Instruction		Machine Code	Function		Flag/Remark
NOP		0000 0000 0000 0000	No Operation		
IDC&		0000 0001 0100 1010	HL	← HL+1	
LCT	Lz, Ry	0000 001Z ZZZZ ZYYY	Lz	← (7SEG ← Ry)	Ry=70H~77H
LCB	Lz, Ry	0000 010Z ZZZZ ZYYY	Lz	← (7SEG ← Ry)	Blank Zero
LCP	Lz, Ry	0000 011Z ZZZZ ZYYY	Lz	← Ry & AC	
LCD	Lz, @HL	0000 100Z ZZZZ Z000	Lz	← T@HL	
LCT	Lz, @HL	0000 100Z ZZZZ Z001	Lz	← (7SEG ← @HL)	
LCB	Lz, @HL	0000 100Z ZZZZ Z010	Lz	← (7SEG ← @HL)	Blank Zero
LCP	Lz, @HL	0000 100Z ZZZZ Z011	Lz	← @HL & AC	
LCDX	D	0000 100D D000 0100	Multi-Lz D=00 D=01 D=10 D=11	← T@HL : Multi-Lz=00H~0FH : Multi-Lz=10H~1FH : Multi-Lz=20H~2FH : Multi-Lz=30H~3FH	
LCTX	D	0000 100D D000 0101	Multi-Lz	← (7SEG ← @HL)	
LCBX	D	0000 100D D000 0110	Multi-Lz	← (7SEG ← @HL)	Blank Zero
LCPX	D	0000 100D D000 0111	Multi-Lz	← @HL & AC	
OPA	Rx	0000 1010 0XXX XXXX	Port (A)	← Rx	
OPAS	Rx, D	0000 1011 DXXX XXXX	A1, 2, 3, 4	← Rx0,Rx1,D,Pulse	
OPB	Rx	0000 1100 0XXX XXXX	Port (B)	← Rx	
OPC	Rx	0000 1101 0XXX XXXX	Port (C)	← Rx	
OPD	Rx	0000 1110 0XXX XXXX	Port (D)	← Rx	
OPE	Rx	0000 1110 1XXX XXXX	Port (E)	← Rx	
FRQ	D, Rx	0001 00DD 0XXX XXXX	FREQ D=00 D=01 D=10 D=11	← Rx & AC : 1/4 Duty : 1/3 Duty : 1/2 Duty : 1/1 Duty	
FRQ	D, @HL	0001 01DD 0000 0000	FREQ	← T@HL	
FRQ#	D, @HL	0001 01DD 0000 1000	FREQ HL	← T@HL ← HL+1	
FRQX	D, X	0001 10DD XXXX XXXX	FREQ	← X	
MVL	Rx	0001 1100 0XXX XXXX	IDBF0~3	← Rx	
MVH	Rx	0001 1101 0XXX XXXX	IDBF4~7	← Rx	
MVU	Rx	0001 1110 0XXX XXXX	IDBF8~11	← Rx	
MVV	Rx	0001 1111 0XXX XXXX	IDBF12~14	← Rx	
ADC	Rx	0010 0000 0XXX XXXX	AC	← Rx + AC + CF	CF
ADC	@HL	0010 0000 1000 0000	AC	← @HL + AC + CF	CF
ADC#	@HL	0010 0000 1100 0000	AC HL	← @HL + AC + CF ← HL+1	CF
ADC	@HL, DA	0010 0000 1001 0000	AC	← BCD(@HL + AC + CF)	CF
ADC#	@HL, DA	0010 0000 1101 0000	AC HL	← BCD(@HL + AC + CF) ← HL+1	CF
ADC*	Rx	0010 0001 0XXX XXXX	AC, Rx	← Rx + AC + CF	CF

Instruction		Machine Code	Function		Flag/Remark
ADC*	@HL	0010 0001 1000 0000	AC, @HL	← @HL + AC + CF	CF
ADC*#	@HL	0010 0001 1100 0000	AC, @HL HL	← @HL + AC + CF ← HL+1	CF
ADC*	@HL, DA	0010 0001 1001 0000	AC, @HL	← BCD (@HL + AC + CF)	CF
ADC*#	@HL, DA	0010 0001 1101 0000	AC, @HL HL	← BCD (@HL + AC + CF) ← HL+1	CF
SBC	Rx	0010 0010 0XXX XXXX	AC	← Rx + ACB + CF	CF
SBC	@HL	0010 0010 1000 0000	AC	← @HL + ACB + CF	CF
SBC#	@HL	0010 0010 1100 0000	AC HL	← @HL + ACB + CF ← HL+1	CF
SBC	@HL, DA	0010 0010 1001 0000	AC	← BCD (@HL + ACB + CF)	CF
SBC#	@HL, DA	0010 0010 1101 0000	AC HL	← BCD (@HL + ACB + CF) ← HL+1	CF
SBC*	Rx	0010 0011 0XXX XXXX	AC, Rx	← Rx + ACB + CF	CF
SBC*	@HL	0010 0011 1000 0000	AC, @HL	← @HL + ACB + CF	CF
SBC*#	@HL	0010 0011 1100 0000	AC, @HL HL	← @HL + ACB + CF ← HL+1	CF
SBC*	@HL, DA	0010 0011 1001 0000	AC, @HL	← BCD (@HL + ACB + CF)	CF
SBC*#	@HL, DA	0010 0011 1101 0000	AC, @HL HL	← BCD (@HL + ACB + CF) ← HL+1	CF
ADD	Rx	0010 0100 0XXX XXXX	AC	← Rx + AC	CF
ADD	@HL	0010 0100 1000 0000	AC	← @HL + AC	CF
ADD#	@HL	0010 0100 1100 0000	AC HL	← @HL + AC ← HL+1	CF
ADD	@HL, DA	0010 0100 1001 0000	AC	← BCD (@HL + AC)	CF
ADD#	@HL, DA	0010 0100 1101 0000	AC HL	← BCD (@HL + AC) ← HL+1	CF
ADD*	Rx	0010 0101 0XXX XXXX	AC, Rx	← Rx + AC	CF
ADD*	@HL	0010 0101 1000 0000	AC, @HL	← @HL + AC	CF
ADD*#	@HL	0010 0101 1100 0000	AC, @HL HL	← @HL + AC ← HL+1	CF
ADD*	@HL, DA	0010 0101 1001 0000	AC, @HL	← BCD (@HL + AC)	CF
ADD*#	@HL, DA	0010 0101 1101 0000	AC, @HL HL	← BCD (@HL + AC) ← HL+1	CF
SUB	Rx	0010 0110 0XXX XXXX	AC	← Rx + ACB + 1	CF
SUB	@HL	0010 0110 1000 0000	AC	← @HL + ACB + 1	CF
SUB#	@HL	0010 0110 1100 0000	AC HL	← @HL + ACB + 1 ← HL+1	CF
SUB	@HL, DA	0010 0110 1001 0000	AC	← BCD (@HL + ACB + 1)	CF
SUB#	@HL, DA	0010 0110 1101 0000	AC HL	← BCD (@HL + ACB + 1) ← HL+1	CF
SUB*	Rx	0010 0111 0XXX XXXX	AC, Rx	← Rx + ACB + 1	CF
SUB*	@HL	0010 0111 1000 0000	AC, @HL	← @HL + ACB + 1	CF
SUB*#	@HL	0010 0111 1100 0000	AC, @HL HL	← @HL + ACB + 1 ← HL+1	CF
SUB*	@HL, DA	0010 0111 1001 0000	AC, @HL	← BCD (@HL + ACB + 1)	CF
SUB*#	@HL, DA	0010 0111 1101 0000	AC, @HL HL	← BCD (@HL + ACB + 1) ← HL+1	CF

Instruction		Machine Code	Function		Flag/Remark
ADN	Rx	0010 1000 0XXX XXXX	AC	← Rx + AC	
ADN	@HL	0010 1000 1000 0000	AC	← @HL + AC	
ADN#	@HL	0010 1000 1100 0000	AC HL	← @HL + AC ← HL+1	
ADN*	Rx	0010 1001 0XXX XXXX	AC, Rx	← Rx + AC	
ADN*	@HL	0010 1001 1000 0000	AC, @HL	← @HL + AC	
ADN*#	@HL	0010 1001 1100 0000	AC, @HL HL	← @HL + AC ← HL+1	
AND	Rx	0010 1010 0XXX XXXX	AC	← Rx AND AC	
AND	@HL	0010 1010 1000 0000	AC	← @HL AND AC	
AND#	@HL	0010 1010 1100 0000	AC HL	← @HL AND AC ← HL+1	
AND*	Rx	0010 1011 0XXX XXXX	AC, Rx	← Rx AND AC	
AND*	@HL	0010 1011 1000 0000	AC, @HL	← @HL AND AC	
AND*#	@HL	0010 1011 1100 0000	AC, @HL HL	← @HL AND AC ← HL+1	
EOR	Rx	0010 1100 0XXX XXXX	AC	← Rx EOR AC	
EOR	@HL	0010 1100 1000 0000	AC	← @HL EOR AC	
EOR#	@HL	0010 1100 1100 0000	AC HL	← @HL EOR AC ← HL+1	
EOR*	Rx	0010 1101 0XXX XXXX	AC,Rx	← Rx EOR AC	
EOR*	@HL	0010 1101 1000 0000	AC, @HL	← @HL EOR AC	
EOR*#	@HL	0010 1101 1100 0000	AC, @HL HL	← @HL EOR AC ← HL+1	
OR	Rx	0010 1110 0XXX XXXX	AC	← Rx OR AC	
OR	@HL	0010 1110 1000 0000	AC	← @HL OR AC	
OR#	@HL	0010 1110 1100 0000	AC HL	← @HL OR AC ← HL+1	
OR*	Rx	0010 1111 0XXX XXXX	AC, Rx	← Rx OR AC	
OR*	@HL	0010 1111 1000 0000	AC, @HL	← @HL OR AC	
OR*#	@HL	0010 1111 1100 0000	AC, @HL HL	← @HL OR AC ← HL+1	
ADCI	Ry, D	0011 0000 DDDD YYYY	AC	← Ry + D + CF	CF
ADCI*	Ry, D	0011 0001 DDDD YYYY	AC, Ry	← Ry + D + CF	CF
SBCI	Ry, D	0011 0010 DDDD YYYY	AC	← Ry + DB + CF	CF
SBCI*	Ry, D	0011 0011 DDDD YYYY	AC, Ry	← Ry + DB + CF	CF
ADDI	Ry, D	0011 0100 DDDD YYYY	AC	← Ry + D	CF
ADDI*	Ry, D	0011 0101 DDDD YYYY	AC, Ry	← Ry + D	CF
SUBI	Ry, D	0011 0110 DDDD YYYY	AC	← Ry + DB + 1	CF
SUBI*	Ry, D	0011 0111 DDDD YYYY	AC, Ry	← Ry + DB + 1	CF
ADNI	Ry, D	0011 1000 DDDD YYYY	AC	← Ry + D	
ADNI*	Ry, D	0011 1001 DDDD YYYY	AC, Ry	← Ry + D	
ANDI	Ry, D	0011 1010 DDDD YYYY	AC	← Ry AND D	
ANDI*	Ry, D	0011 1011 DDDD YYYY	AC, Ry	← Ry AND D	
EORI	Ry, D	0011 1100 DDDD YYYY	AC	← Ry EOR D	
EORI*	Ry, D	0011 1101 DDDD YYYY	AC, Ry	← Ry EOR D	

Instruction		Machine Code	Function		Flag/Remark
ORI	Ry, D	0011 1110 DDDD YYYY	AC	← Ry OR D	
ORI*	Ry, D	0011 1111 DDDD YYYY	AC, Ry	← Ry OR D	
INC*	Rx	0100 0000 0XXX XXXX	AC, Rx	← Rx + 1	CF
INC*	@HL	0100 0000 1000 0000	AC, @HL	← @HL + 1	CF
INC*#	@HL	0100 0000 1100 0000	AC, @HL HL	← @HL + 1 ← HL+1	CF
DEC*	Rx	0100 0001 0XXX XXXX	AC, Rx	← Rx - 1	CF
DEC*	@HL	0100 0001 1000 0000	AC, @HL	← @HL - 1	CF
DEC*#	@HL	0100 0001 1100 0000	AC, @HL HL	← @HL - 1 ← HL+1	CF
MWM	Rm, Ry	0100 0100 MMMM YYYY	Rm	← Ry	
MMW	Ry, Rm	0100 0101 MMMM YYYY	AC, Ry	← Rm	
IPA	Rx	0100 0110 0XXX XXXX	AC, (Rx)	← Port(A)	
IPB	Rx	0100 0110 1XXX XXXX	AC, (Rx)	← Port(B)	
IPC	Rx	0100 0111 0XXX XXXX	AC, Rx	← Port(C)	
IPD	Rx	0100 1000 0XXX XXXX	AC, Rx	← Port(D)	
IPE	Rx	0100 1000 1XXX XXXX	AC, Rx	← Port(E)	
LDS	@HL, D	0100 1001 1000 DDDD	AC, @HL	← D	
LDS#	@HL, D	0100 1001 1100 DDDD	AC, @HL HL	← D ← HL+1	
MAF	Rx	0100 1010 0XXX XXXX	AC, Rx	← STS1	B3: CF B2: ZERO B1: (No use) B0: (No use)
RTM2L	Rx	0100 1010 1XXX XXXX	AC, (Rx)	← TM2 (0~3)	
MSB	Rx	0100 1011 0XXX XXXX	AC, Rx	← STS2	B3: SCF3 (DPT) B2: SCF2 (HRx) B1: SCF1 (CPT) B0: BCF
RTM21	Rx	0100 1011 1XXX XXXX	AC, (Rx)	← TM2 (4, 5), 1 (0, 1)	
MSC	Rx	0100 1100 0XXX XXXX	AC, Rx	← STS3	B3: SCF7 (PDV) B2: PH15 B1: SCF5 (TM1) B0: SCF4 (INT)
RTM1H	Rx	0100 1100 1XXX XXXX	AC, (Rx)	← TM1 (2~5)	
MCX	Rx	0100 1101 0XXX XXXX	AC, Rx	← STS3X	B3: SCF9(RFC) B2: (No use) B1: SCF6 (TM2) B0: SCF8 (SKI)
MSD	Rx	0100 1110 0XXX XXXX	AC, Rx	← STS4	B3: (No use) B2: RFOVF B1: WDF B0: CSF
MDX	Rx	0100 1111 0XXX XXXX	AC, Rx	← STS4X	B3: (No use) B2: INT B1: (No use) B0: (No use)
SR0	Rx	0101 0000 0XXX XXXX	ACn, Rxn AC3, Rx3	← Rx (n+1) ← 0	

Instruction		Machine Code	Function		Flag/Remark
SR1	Rx	0101 0000 1XXX XXXX	ACn, (Rx)n AC3, (Rx)3	← (Rx) (n+1) ← 1	
SL0	Rx	0101 0001 0XXX XXXX	ACn, (Rx)n AC0, (Rx)0	← (Rx) (n-1) ← 0	
SL1	Rx	0101 0001 1XXX XXXX	ACn, (Rx)n AC0, (Rx)0	← (Rx) (n-1) ← 1	
RRC	Rx	0101 0010 0XXX XXXX	ACn, (Rx)n AC3, (Rx)3 CF	← (Rx) (n+1) ← CF ← (Rx) 0	CF ' ': B6=0 '#': B6=1
RRC RRC#	@HL	0101 0010 1B00 0000	ACn, (@HL) n AC3, (@HL) 3 CF '#': HL	← (@HL) (n+1) ← CF ← (@HL) 0 ← HL+1	
RLC	Rx	0101 0011 0XXX XXXX	ACn, (Rx) n AC0, (Rx) 0 CF	← (Rx) (n-1) ← CF ← (Rx) 3	CF ' ': B6=0 '#': B6=1
RLC RLC#	@HL	0101 0011 1B00 0000	ACn, (@HL) n AC0, (@HL) 0 CF '#': HL	← (@HL) (n-1) ← CF ← (@HL) 3 ← HL+1	
DAA		0101 0100 0000 0000	AC	← BCD (AC)	
DAA*	Rx	0101 0101 0XXX XXXX	AC, Rx	← BCD (AC)	
DAA*	@HL	0101 0101 1000 0000	AC, @HL	← BCD (AC)	
DAA*#	@HL	0101 0101 1100 0000	AC, @HL HL	← BCD (AC) ← HL+1	
DAS		0101 0110 0000 0000	AC	← BCD (AC)	
DAS*	Rx	0101 0111 0XXX XXXX	AC, Rx	← BCD (AC)	
DAS*	@HL	0101 0111 1000 0000	AC, @HL	← BCD (AC)	
DAS*#	@HL	0101 0111 1100 0000	AC, @HL HL	← BCD (AC) ← HL+1	
LDS	Rx, D	0101 1DDD DXXX XXXX	AC, Rx	← D	
LDH	Rx, @HL	0110 0000 0XXX XXXX	AC, Rx	← H (T@HL)	
LDH*	Rx, @HL	0110 0001 0XXX XXXX	AC, Rx HL	← H (T@HL) ← HL + 1	
LDL	Rx, @HL	0110 0010 0XXX XXXX	AC, Rx	← L (T@HL)	
LDL*	Rx, @HL	0110 0011 0XXX XXXX	AC, Rx HL	← L (T@HL) ← HL + 1	
MRF1	Rx	0110 0100 0XXX XXXX	AC, Rx	← RFC3-0	
MRF2	Rx	0110 0101 0XXX XXXX	AC, Rx	← RFC7-4	
MRF3	Rx	0110 0110 0XXX XXXX	AC, Rx	← RFC11-8	
MRF4	Rx	0110 0111 0XXX XXXX	AC, Rx	← RFC15-12	
STA	Rx	0110 1000 0XXX XXXX	Rx	← AC	
STA	@HL	0110 1000 1000 0000	@HL	← AC	
STA#	@HL	0110 1000 1100 0000	@HL HL	← AC ← HL+1	
LDA	Rx	0110 1100 0XXX XXXX	AC	← Rx	
LDA	@HL	0110 1100 1000 0000	AC	← @HL	

Instruction		Machine Code	Function		Flag/Remark
LDA#	@HL	0110 1100 1100 0000	AC HL	← @HL ← HL+1	
MRA	Rx	0110 1101 0XXX XXXX	CF	← Rx3	
MRW	@HL, Rx	0110 1110 0XXX XXXX	AC, @HL	← Rx	
MRW#	@HL, Rx	0110 1110 1XXX XXXX	AC, @HL HL	← Rx ← HL+1	
MWR	Rx, @HL	0110 1111 0XXX XXXX	AC, Rx	← @HL	
MWR#	Rx, @HL	0110 1111 1XXX XXXX	AC, Rx HL	← @HL ← HL+1	
MRW	Ry, Rx	0111 0YYY YXXX XXXX	AC, Ry	← Rx	
MWR	Rx, Ry	0111 1YYY YXXX XXXX	AC, Rx	← Ry	
JB0	X	1000 0XXX XXXX XXXX	PC	← X(x000h~x7FFh ; x800~xFFFh)	if AC0=1
JB1	X	1000 1XXX XXXX XXXX	PC	← X(x000h~x7FFh ; x800~xFFFh)	if AC1=1
JB2	X	1001 0XXX XXXX XXXX	PC	← X(x000h~x7FFh ; x800~xFFFh)	if AC2=1
JB3	X	1001 1XXX XXXX XXXX	PC	← X(x000h~x7FFh ; x800~xFFFh)	if AC3=1
JNZ	X	1010 0XXX XXXX XXXX	PC	← X(x000h~x7FFh ; x800~xFFFh)	if AC≠0
JNC	X	1010 1XXX XXXX XXXX	PC	← X(x000h~x7FFh ; x800~xFFFh)	if CF=0
JZ	X	1011 0XXX XXXX XXXX	PC	← X(x000h~x7FFh ; x800~xFFFh)	if AC=0
JC	X	1011 1XXX XXXX XXXX	PC	← X(x000h~x7FFh ; x800~xFFFh)	if CF=1
CALL	X	1100 XXXX XXXX XXXX	STACK PC	← PC+1 ← X(0000h~3DFFh)	Jump BANK is processed by Compiler.
JMP	X	1101 XXXX XXXX XXXX	PC	← X(0000h~3DFFh)	
TMS	Rx	1110 0000 0XXX XXXX	AC3, 2=11 AC3, 2=10 AC3, 2=01 AC3, 2=00 AC1, 0, PB3~0	: Ctm=FREQ : Ctm=PH15 : Ctm=PH3 : Ctm=PH9 : Set Timer1 Value	
TMS	@HL	1110 0001 0000 0000	TD7, 6=11 TD7, 6=10 TD7, 6=01 TD7, 6=00 TD5~0	: Ctm=FREQ : Ctm=PH15 : Ctm=PH3 : Ctm=PH9 : Set Timer1 Value	
TMS#	@HL	1110 0001 0000 1000	TD7, 6=11 TD7, 6=10 TD7, 6=01 TD7, 6=00 TD5~0 HL	: Ctm=FREQ : Ctm=PH15 : Ctm=PH3 : Ctm=PH9 : Set Timer1 Value ← HL+1	
TMSX	X	1110 001X XXXX XXXX	X8, 7, 6=111 X8, 7, 6=110 X8, 7, 6=101 X8, 7, 6=100 X8, 7, 6=011	: Ctm=PH13 : Ctm=PH11 : Ctm=PH7 : Ctm=PH5 : Ctm=FREQ	

Instruction		Machine Code	Function		Flag/Remark
			X8, 7, 6=010 X8, 7, 6=001 X8, 7, 6=000 X5~0	: Ctm=PH15 : Ctm=PH3 : Ctm=PH9 : Set Timer1 Value	
TM2	Rx	1110 0100 0XXX XXXX	Timer2	← Rx & AC	
TM2	@HL	1110 0101 0000 0000	Timer2	← T@HL	
TM2#	@HL	1110 0101 0000 1000	Timer2 HL	← T@HL ← HL+1	
TM2X	X	1110 011X XXXX XXXX	X8, 7, 6=111 X8, 7, 6=110 X8, 7, 6=101 X8, 7, 6=100 X8, 7, 6=011 X8, 7, 6=010 X8, 7, 6=001 X8, 7, 6=000 X5~0	: Ctm=PH13 : Ctm=PH11 : Ctm=PH7 : Ctm=PH5 : Ctm=FREQ : Ctm=PH15 : Ctm=PH3 : Ctm=PH9 : Set Timer2 Value	
SHE	X	1110 1000 0XXX XXX0	X6 X5 X4 X3 X2 X1	: Enable HEF6 : Enable HEF5 : Enable HEF4 : Enable HEF3 : Enable HEF2 : Enable HEF1	RFC KEY_S TMR2 PDV INT TMR1
SIE*	X	1110 1001 0XXX XXXX	X6 X5 X4 X3 X2 X1 X0	: Enable IEF6 : Enable IEF5 : Enable IEF4 : Enable IEF3 : Enable IEF2 : Enable IEF1 : Enable IEF0	RFC KEY_S TMR2 PDV INT TMR1 C, DPT
PLC	X	1110 101X 0XXX XXXX	X8 X6-0	: Reset PH15~11 : Reset HRF6-0	
SRF	X	1110 1100 0XXX XXXX	X6,5,4=000 X6,5,4=001 X6,5,4=010 X6,5,4=011 X6,5,4=100 X6,5,4=101 X6,5,4=111 X3 X2 X1 X0	Control Mode : Software (Crfc=CX) : TM2 (Crfc=CX) : CX – One Cycle : CX – High Level : Software (Crfc=FREQ) : TM2 (Crfc=FREQ): : CX – Rising Edge : Enable Counter : Enable RH Output : Enable RT Output : Enable RR Output	ENX EHM ETP ERR
SRE	X	1110 1101 X0XX X000	X7 X5 X4 X3	: Enable SRF7 : Enable SRF5 : Enable SRF4 : Enable SRF3	SRF7(KEY_S) SRF5 (INT) SRF4 (C Port) SRF3 (D port)
FAST	(X)	1110 1110 0000 0XXX	B/SCLK X=7 X=6 X=5 X=4	: High Speed Clock : B/SCLK=FTOSC/128 : B/SCLK=FTOSC/64 : B/SCLK=FTOSC/32 : B/SCLK=FTOSC/16	

Instruction		Machine Code	Function		Flag/Remark
			X=3 X=2 X=1 X=0 or None	: B/SCLK=FTOSC/8 : B/SCLK=FTOSC/4 : B/SCLK=FTOSC/2 : B/SCLK=FTOSC	
SLOW		1110 1110 1000 0000	SCLK	: Low Speed Clock	
CPHL	X	1110 1111 XXXX XXXX	(PC+1)	← force “NOP”	if X7~0=IDBF7~0
SPK	Rx	1111 0000 0XXX XXXX	KO1~16	← Rx & AC	
SPK	@HL	1111 0001 0000 0000	KO1~16	← T @HL	
SPK#	@HL	1111 0001 0000 1000	KO1~16 HL	← T @HL ← HL+1	
SPKX	X	1111 0010 XXXX XXXX	X6=1 X6=0 X7, 5, 4=000 X7, 5, 4=001 X7, 5, 4=010 X7, 5, 4=10X X7, 5, 4=110 X7, 5, 4=111	: KEY_S release by scanning cycle : KEY_S release by normal key scanning : Set one of KO1~16=1 by X3~0 : Set all=1 : Set all Hi-z : Set eight of KO1~16=1 by X3 X3=0=> KO1~8 X3=1=> KO9~16 : Set four of KO1~16=1 by X3, 2 X3, 2=00=> KO1~4 X3, 2=01=> KO5~8 X3, 2=10=> KO9~12 X3, 2=11=> KO13~16 : Set two of KO1~16=1 by X3, 2, 1 X3~1=000=> KO1, 2 X3~1=001=> KO3, 4 X3~1=010=> KO5, 6 X3~1=011=> KO7, 8 X3~1=100=> KO9, 10 X3~1=101=> KO11, 12 X3~1=110=> KO13, 14 X3~1=111=> KO15, 16	
RTS		1111 0100 0000 0000	PC	← STACK	CALL Return
SBZ	X	1111 0100 0010 00XX	X1=0 X1=1 X0=0 X0=1	<set BZB Pad> : BZB : FREQB only <set BZ Pad> : BZ : FREQ only	Initial Initial
SWPWR	X	1111 0100 0010 01XX	X1,0=0X X1,0=10 X1,0=11	: Power Mode by Code Option : Switch to 3.0V Power Mode, BCF=0 : BAK<VBAT : Switch to 1.5V Power Mode	Initial
SRP	X	1111 0100 0010 1XXX	X1 X0	: Enable Timer2 repeat set if RL2=1 : Enable Timer1 repeat set if RL1=1	
DISTM	X	1111 0100 0011 10XX	X1~0	: Disable TM2~1 Count	
SCC	X	1111 0100 1X0X XXXX	X6=1 X6=0 X4=1	: Cfq=BCLK : Cfq=PH0 Set P (C) Cch	

Instruction		Machine Code	Function		Flag/Remark
			X3=1 X2, 1, 0=001 X2, 1, 0=010 X2, 1, 0=100	Set P (D) Cch : Cch=PH10 : Cch=PH8 : Cch=PH6	
SCA	X	1111 0101 000X X000	X4 X3	: Enable SEF4 : Enable SEF3	C1-4 D1-4
SPE	X	1111 0101 010X XXXX	X4 X3~0	: Set E4-1 Pull-Low : Set E4-1 I/O	
SPA	X	1111 0101 100X XXXX	X4 X3~0	: Set A4-1 Pull-Low : Set A4-1 I/O	
SPB	X	1111 0101 101X XXXX	X4 X3~0	: Set B4-1 Pull-Low : Set B4-1 I/O	
SPC	X	1111 0101 110X XXXX	X4 X3-0	: Set C4-1 Pull-Low/Low-Level-Hold : Set C4-1 I/O	
SPD	X	1111 0101 111X XXXX	X4 X3-0	: Set D4-1 Pull-Low : Set D4-1 I/O	
SF	X	1111 0110 X0XX XXXX	X7 X5 X4 X3 X2 X1 X0	: Reload 1 Set : Enable all Timer Counter update & latch : WDT Enable : HALT after EL : EL LIGHT On : BCF Set : CF Set	RL1 WDF BCF CF
RF	X	1111 0111 X0XX 0XXX	X7 X5 X4 X2 X1 X0	: Reload 1 Reset : Disable all Timer Counter latch : WDT Reset : EL LIGHT Off : BCF Reset : CF Reset	RL1 WDF BCF CF
ELC	X	1111 10XX XXXX XXXX	X8, 7, 6=111 X8, 7, 6=110 X8, 7, 6=101 X8, 7, 6=100 X8, 7, 6=011 X8, 7, 6=000 X9, 5, 4=101 X9, 5, 4=100 X9, 5, 4=x11 X9, 5, 4=x10 X9, 5, 4=001 X9, 5, 4=000 X3, 2=11 X3, 2=10 X3, 2=01 X3, 2=00 X1, 0=11 X1, 0=10 X1, 0=01 X1, 0=00	BCLK/8 BCLK/4 BCLK/2 BCLK FREQB PH0 2/3 3/4 1/1 1/2 1/3 1/4 PH5 PH6 PH7 PH8 1/1 1/2 1/3 1/4	ELP - CLK ELP - DUTY ELC - CLK ELC - DUTY
ALM	X	1111 110X XXXX XXXX	X8, 7, 6=111 X8, 7, 6=100 X8, 7, 6=011	: FREQ : DC1 : PH3	

Instruction		Machine Code	Function		Flag/Remark
			X8, 7, 6=010 X8, 7, 6=001 X8, 7, 6=000 X5~0	: PH4 : PH5 : DC0 ← PH15~10	
SF2	X	1111 1110 0BBB XXXX	B6 B5,4=00 B5,4=01 B5,4=10 B5,4=11 X3 X2 X1 X0	: Enable set Program ROM bank & jump. : PC=0XXXh : PC=1XXXh : PC=2XXXh : PC=3XXXh : Enable INT powerful Pull-low : Close all Segments : Dis-ENX Set : Reload 2 Set	B6,5,4 used by compiler INTPL RSOFF DED RL2
RF2	X	1111 1110 1000 XXXX	X3 X2 X1 X0	: Disable INT powerful Pull-low : Release Segments : Dis-ENX Reset : Reload 2 Reset	INTPL RSOFF DED RL2
HALT		1111 1111 0000 0000	Halt Operation		
STOP		1111 1111 1000 0000	Stop Operation		

Symbol Description

AC	: Accumulator	D	: Immediate Data
ACB	: Invert of Accumulator	DB	: Invert of Immediate Data
ACn	: Accumulator bit n	PC	: Program Counter
X	: Address or Set data	CF	: Carry Flag
Rx	: Address of Data RAM	ZERO	: Zero Flag
(Rx) n	: Bit n of (Rx)	WDF	: Watch-Dog Timer Enable Flag
Ry	: Address of working register	PDV	: Pre-Divider
BCF	: Back-up Flag	BCLK	: System clock stop only in STOP condition
IEFn	: Interrupt Enable Flag	SEFn	: Switch Enable Flag
HRFn	: HALT Release Flag	SRFn	: STOP Release Enable Flag
HEFn	: HALT Release Enable Flag	SCFn	: Start Condition Flag
TMR	: Timer Overflow Release Flag	Cch	: Clock Source of Chattering Detector
Ctm	: Clock Source of Timer	Cfq	: Clock Source of Frequency Generator
Lz	: Address of LCD data	FREQ	: Frequency Generator setting Value
RFOVF	: RFC Overflow Flag	()	: Content of Address Register
@HL	: Address assigned by Index Register	HL	: Index Register
H (T@HL)	: High Nibble of Index ROM data	L (T@HL)	: Low Nibble of Index ROM Data
IDBF	: Content of Index Register	T@HL	: Index ROM address assigned by Index Register
CSF	: Clock Source Flag	DA	: BCD for result
FTOSC	: Fast Oscillation clock		

MWM/MMW Rm Assignment

Rm	R/W	Instruction	BIT3	BIT2	BIT1	BIT0
0	R	MMW Ry, 0	IPF3	IPF2	IPF1	IPF0
	W	MWM 0, Ry	OPF3	OPF2	OPF1	OPF0
1	W	MWM 1, Ry	SPF3	SPF2	SPF1	SPF0
2	R	MMW Ry, 2	IPG3	IPG2	IPG1	IPG0
	W	MWM 2, Ry	OPG3	OPG2	OPG1	OPG0
3	W	MWM 3, Ry	SPG3	SPG2	SPG1	SPG0
4~7	Don't Use					
8	W	MWM 8, Ry	0	0	SPLG	SPLF
9	R	MMW Ry, 9	LVR2F	LBD4	-	LBF
	W	MWM 9, Ry	CLRLVR2/ LVR2RLS		0	ENLBD
A	R	MMW Ry, A	VDL3	VDL2	VDL1	VDL0
	W	MWM A, Ry				
B	R	MMW Ry, B	LBD3	LBD2	LBD1	LBD0
	W	MWM B, Ry				
C~E	Don't Use					
F	R	MMW Ry, F	VDX3	VDX2	VDX1	VDX0
	W	MWM F, Ry				

IPF3~0 : IOF4~1 input Data.
 OPF3~0 : set IOF4~1 output data.
 SPF3~0 : 1 for set IOF4~1 to Output(initial value = 0000).
 SPLF : 1 for enable IOF4~1 Pull-low(initial value = 1).

IPG3~0 : IOFG~1 input Data.
 OPG3~0 : set IOFG~1 output data.
 SPG3~0 : 1 for set IOG4~1 to Output(initial value = 0000).
 SPLG : 1 for enable IOFG~1 Pull-low(initial value = 1).

LBF : Low Battery Detect Flag.
 ENLBD : 1 for generating pulse to enable Low Battery Detect.
 LVR2F : Reset by LVR2 Flag & can be clear by CLRLVR2=1 if set LVR2 to LVR by code option.
 LBD/SWPWR state if set LVR2 to auto-LBD/SWPWR by code option(SWPWR instruction will be disable if set LVR2 to auto-SWPWR, LVR2F=0/1 for 3/1.5V Power Mode).
 CLRLVR2 : Clear LVR2F if set LVR2 to LVR by code option.
 LVR2RLS : Enable LVR2F 1<->0 Halt/Interrupt Release by share with INT if set LVR2 to auto-LBD/SWPWR by code option.
 VDL3~0 : Set VDL regulator output voltage.
 ±50mV for one step voltage.
 <VDL for VL2>
 Initial value=6h for VDL=2.10V.
 VDL=2.55/1.80V for VL3~0=F/0h.
 <VDL for VL1>



Initial value=2h for VDL=1.05V.

VDL=1.70/0.95V for VL3~0=F/0h.

LBD4~0 : Set Low Battery Detect Voltage.

±50mV for one step voltage.

Initial value=15/00 for LBD=2.40/1.35V at 3/1.5V Power Mode.

LBD=2.90/1.35V for LBD4~0=1F/00h.

Share to set LVR2 voltage if set LVR2 to auto-LBD by code option.

VDX3~0 : Set VDX regulator output voltage.

Initial value=0h for VREG=1.20V.

VDX=1.95/1.20V for VDX3~0=F/0h.